

Technical Data

4000 Series

4012-46TWG4A

Diesel Engine - ElectropaK

1800 rev/min

Basic technical data

Number of cylinders	12
Cylinder arrangement	Vee 60°
Cycle	4 stroke, compression ignition
Induction system	turbocharged
Combustion system.....	direct injection
Compression ratio	13:1 nominal
Bore.....	160 mm
Stroke	190 mm
Cubic capacity.....	45,482 litres
Direction of rotation	Anti clockwise viewed on flywheel
Firing order	1 ^A ,6 ^B ,5 ^A ,2 ^B ,3 ^A ,4 ^B ,6 ^A ,1 ^B ,2 ^A ,5 ^B ,4 ^A ,3 ^B
Cylinder 1.....	furthest from flywheel

Note: Cylinders designated 'A' are on the right hand side of the engine when viewed from the flywheel end.

Total weight of ElectropaK

Engine - dry.....	4440 kg
ElectropaK - wet ⁽¹⁾ ⁽²⁾	5615 kg

1. Includes fuel cooler.

2. Includes engine lubricating oil and water jacket

Overall dimensions of ElectropaK

Height	2255 mm
Length	3714 mm
Width	1780 mm

Moment of inertia (mk²)

Flywheel	9,57 kgm ²
Engine.....	9,73 kgm ²

Cyclic irregularity

For engine/flywheel maximum 1:1147

Ratings

Steady state speed stability at constant load ± 0,25%
Electrical ratings are based on average alternator efficiency and are for guidance only (0.8 power factor being used).

Operating point

Engine speed rev/min
Static injection timing spill timing 20°
Cooling water exit temperature < 98 °C
Fuel data to conform to: BS2869 class A2

Performance

Note: All data based on operation to ISO 3046/1, BS 5514 and DIN 6271 standard reference conditions.

Highest estimated sound pressure level at 1 metre 112 d(B)A
Additional noise data is shown at rear of this document

Test conditions

-air temperature.....25 °C
-barometric pressure100 kPa
-relative humidity 30%
-air inlet restriction at maximum power (nominal)..... 2,5 kPa
-exhaust back pressure at maximum power (nominal).... 3,0 kPa
-maximum fuel temperature (inlet pump)58 °C

For engines operating in ambient conditions other than the standard reference conditions stated below, a suitable de-rate must be applied. De-rate curves for increased ambient temperatures and / or altitude are available on the Perkins Intranet site.

For test conditions relevant to data on load acceptance, please refer to " Cold start recommendations on page 9" of this document.

General installation - 4012-46TWG4A 60hz

Designation	Units	Type of operation and application	
		Prime	Standby
Gross engine power	kWb	1308	1396
Fan and battery charging alternator power	kW	54	
Net engine power	kWm	1254	1342
Brake mean effective pressure (gross)	kPa	1902	2035
Combustion air flow at ISO conditions	m ³ /min	119	122
Exhaust gas temperature (max) after turbo	°C	505	
Exhaust gas flow (max) at atmospheric pressure	m ³ /min	325	
Boost pressure ratio	:1	3,3	3,4
Mechanical efficiency	%	90	90
Overall thermal efficiency (nett)	%	37	38
Friction and pumping power losses	kWm	130	
Mean piston speed	m/s	11.4	
Engine coolant flow	l/min	1000	
Typical GenSet electrical output (0.8pf)	kVA	1500	1600
	kWe	1200	1280
Assumed alternator efficiency	%	96	

Note: Not to be used for CHP design purposes (indicative figures only). Consult Perkins Engines Stafford Limited. Assumes complete combustion.

Rating definitions

Prime Power

Variable load. Unlimited hours usage with an average load factor of 80% of the published Prime Power over each 24 hour period. A 10% overload is available for 1 hour in every 12 hours operation except where stated.

Standby power

Limited to 500 hours annual usage with an average load factor of 80% of the published Standby Power rating over each 24 hour period. Up to 300 hours of annual usage may be run continuously. No overload is permitted on Standby Power.

Emissions capability

All 4012-46TWG ratings are optimised to the 'best fuel consumption' and do not comply to Harmonised International Regulation Emission Limits. More information on these statements can be obtained by contacting the Applications Department at Perkins Engines Company Limited.

4012-46TWG4A - Left view

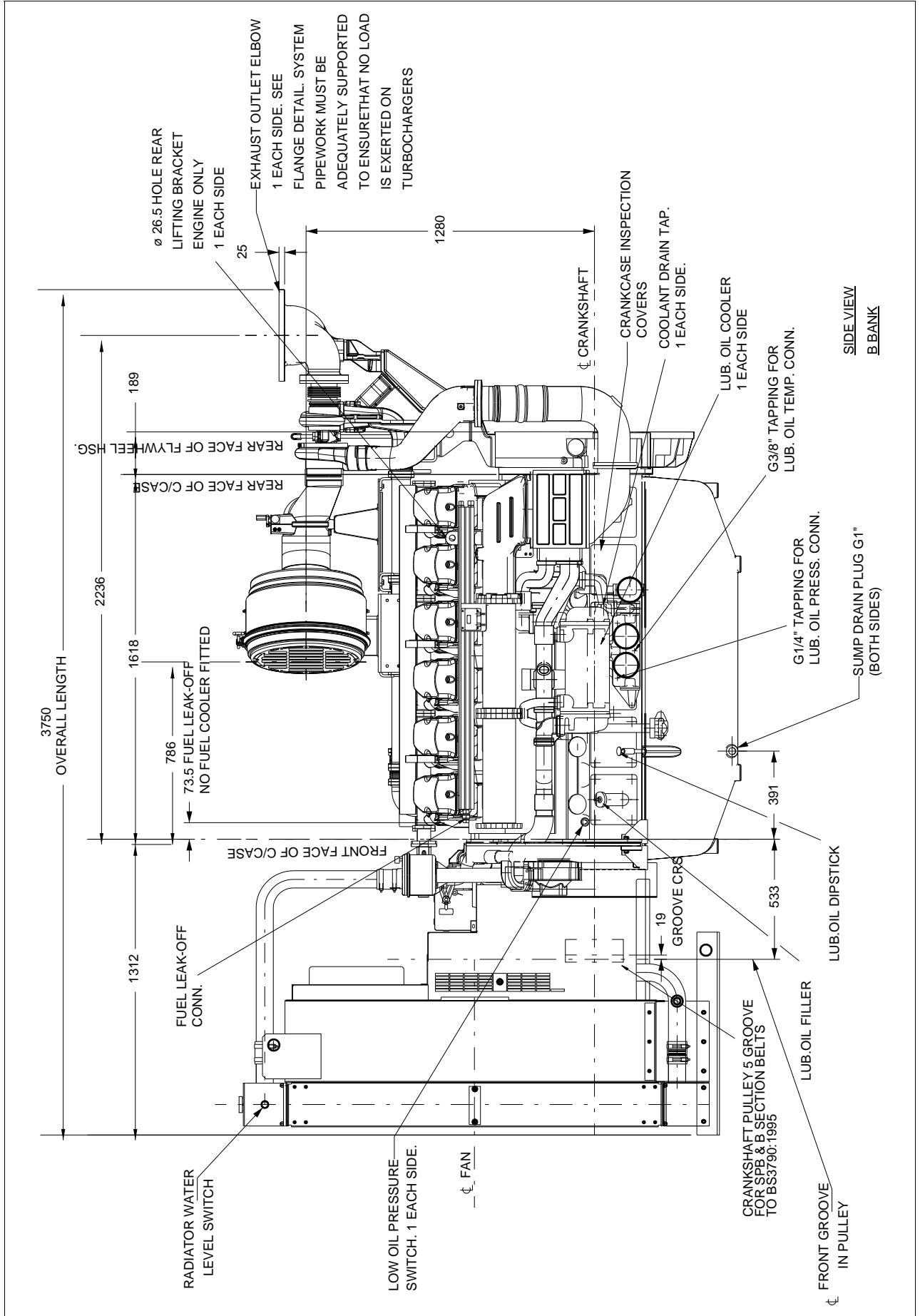

4012-46TWG4A - Front view

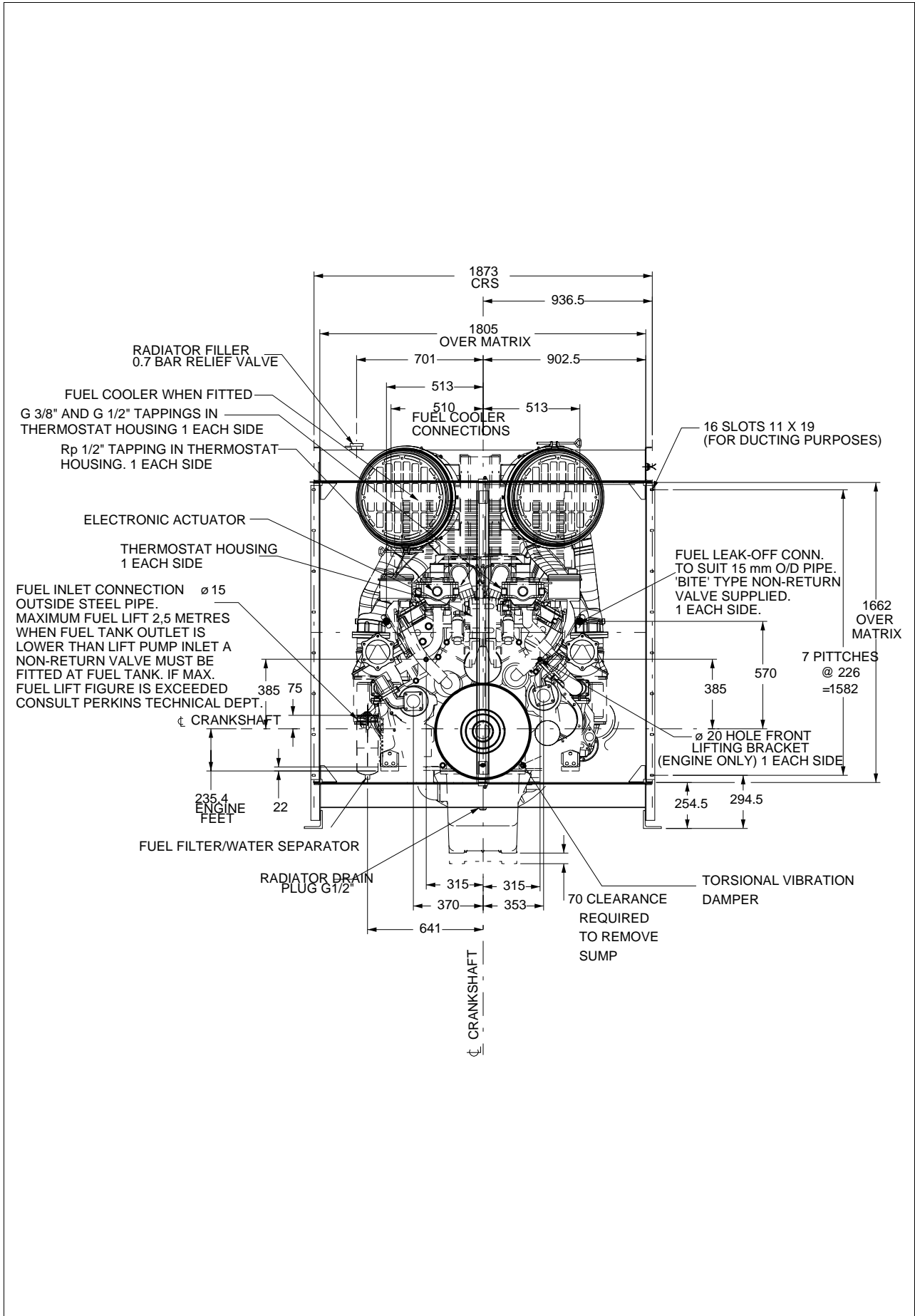

4012-46TWG4A - Rear view

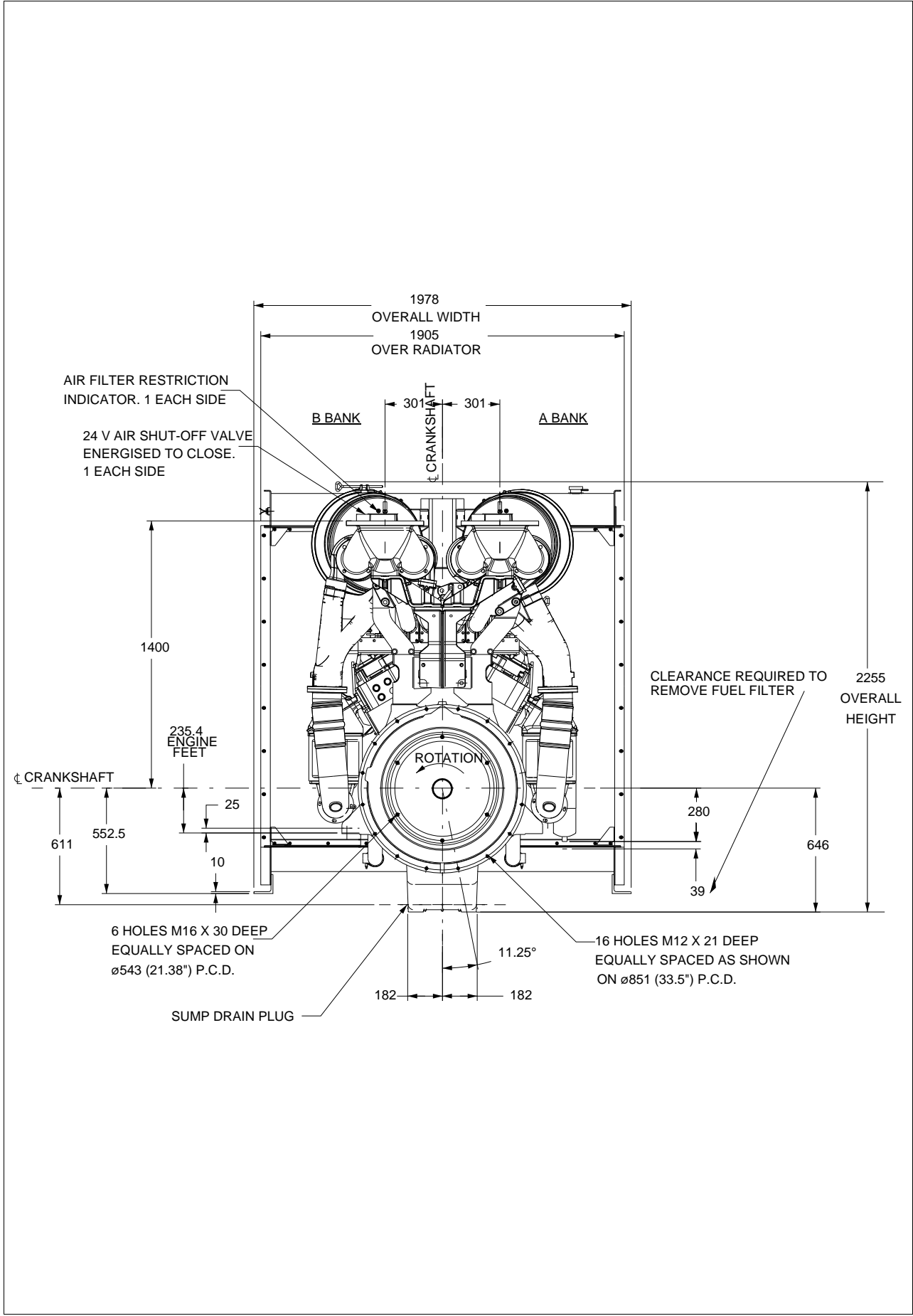

4012-46TWG4A - Support pads, exhaust outlet flange and flywheel details

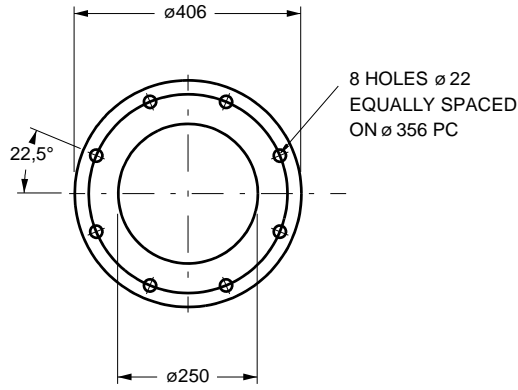

DETAIL OF EXHAUST OUTLET FLANGE
(B.S.10 TABLE D)
SCALE 1:5

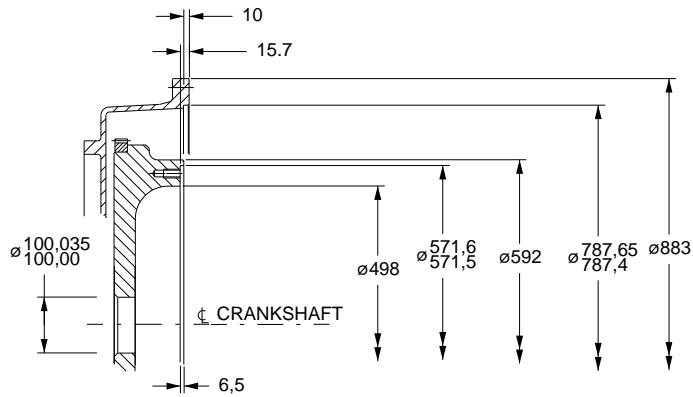

DETAIL OF SAE 518 FLYWHEEL
AND SAE 00 FLYWHEEL HOUSING
(METRIC TAPPINGS)
SCALE 1:5

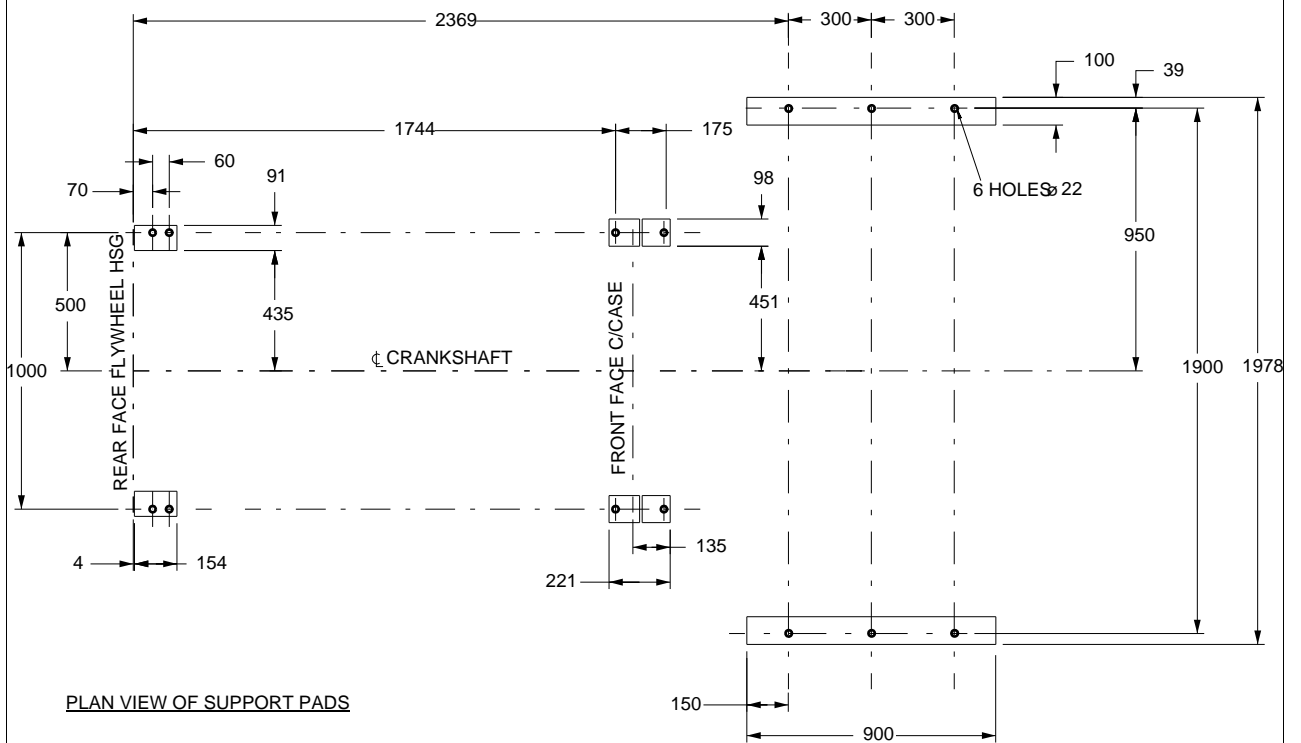

Cooling system

Recommended coolant: 50% inhibited ethylene glycol or 50% inhibited propylene glycol and 50% clean fresh water. For CHP systems and where there is no likelihood of ambient temperature below 10 °C, then clean 'soft' water may be used, treated with 1% by volume of Perkins inhibitor in the cooling system. The inhibitor is available in 1 litre bottles from all Perkins Distributors.

Maximum pressure in crankcase water jacket ... 170 kPa
 Maximum top tank temperature (standby) ... 98 °C
 Maximum static pressure on pump ... 70 kPa
 Ambient cooling clearance (standby power) with air temperature at fan of 6 °C above the ambient ... 38 °C

Total coolant capacity

ElectropaK (engine and radiator) ... 201 litres
 Maximum permissible restriction to coolant pump flow... 20 kPa
 Thermostat operating range... 71 - 85 °C
 Temperature rise across the engine (standby power) with inhibited coolant ... 13 °C
 Shutdown switch setting ... 101 °C (rising)
 Coolant immersion heater capacity ... 2 x 4 kW

Water jacket cooling data

Coolant flow ... 1000 l/min
 Coolant exit temperature (max) ... 98 °C
 Coolant inlet temperature (min) ... 70 °C
 Coolant inlet temperature (max) ... 85 °C

Coolant pump

-speed ... 1.4 x engine rev/min
 -method of drive. ... engine (gear) driven

Radiator

Face area ... 2967420 mm²
 Number of rows and material. ... 226
 Fins per inch and material... 7
 Width of matrix ... 1805 mm
 Height of matrix... 1644 mm
 Weight (dry) ... 843 kg
 Total coolant capacity ... 128 litres
 Pressure cap setting (min). ... 69 kPa

Fan

Type ... engine driven
 Diameter ... 1530 mm
 Number of blades... 12
 Material ... Aluminium
 Drive ratio... 1:0,74

Cooling clearance

4012-46TWG4A - Prime and Standby

Maximum additional restriction (duct allowance) to cooling airflow, and resultant min airflow			
Description	°C	Pa	m ³ /min
Ambient clearance: Inhibited coolant	38	N/A	N/A
Duct allowance	38	0	N/A
Minimum airflow	38	0	1938

Fuel system

Injection system... direct injection
 Fuel injection pump/Injector type. ... Delphi unit injector
 Injector pressure ... 23,4 MPa
 Fuel lift pump type ... Gerotor
 Delivery flow ... 1200 litres/hr
 Heat retained in fuel to tank ... 9,5 kW
 Fuel inlet temperature to be less than ... 58 °C
 Delivery pressure ... 300 kPa
 Maximum suction head at pump inlet... 24,5 kPa
 Maximum static pressure head ..see installation manual for details
 Fuel filter spacing ... 10 microns
 Governing type ... electronic
 Governing ... to ISO 8528-5 2005
 Torque at the governor output shaft ... 1.631
 Tolerance on fuel consumption ... to ISO 8528-1 1993

Fuel specification

Fuel Density @ 15 °C... 0,862 kg/litre
 Recommended fuel see OMM

Fuel consumption

Note: All fuel consumption figures are based on assumed fuel density of 0.862 and Nett rated powers

4012-46TWG4A

Designation	Fuel consumption calculated on nett rated powers	
	g/kWh	litres/hr
Standby power	222	355
100% of Prime power	222	323
75% of Prime power	220	257
50% of Prime power	225	175

Electrical system

Alternator
 -type ... insulated return
 -voltage ... 24 volts
 -output ... 40 amps
 Starter
 -type ... (axial) electric
 -motor voltage ... 24 volts
 -motor power ... 16,4 kW
 Number of teeth on
 -flywheel ... 156
 -starter motor... 12
 Minimum cranking speed ... 120 rev/min
 Starter solenoid (24V)
 -pull in current @ -25 °C max... 30 amps
 -hold in current @ -25 °C max. ... 9 amps
 Engine stop solenoid current... 1,1 amps
 Engine stop solenoid voltage ... 24 volts

Engine mounting

Maximum static bending moment at rear face of block .. 1356 Nm
 Maximum additional load applied to flywheel due to rotating components. ... 850 kg

Centre of gravity

Bare engine (wet) 4012-46TWG4A
 -forward of rear face of cylinder block ... 658 mm
 -above crankshaft centre line ... 32 mm
 ElectropaK (wet)
 -forward of rear face of cylinder block ... 1286 mm
 -above crankshaft centre line .. 32 mm

Cold start recommendations

Temperature range	
Down to 0 °C (32 °F)	Oil: API CH4 15W40 Starter: 2 x 24 volts Battery: 4 x 12V 286 Ah Max breakaway current: 1600 amps Cranking current: 810 amps Aids: N/A Min mean cranking speed: 120 rev/min

Notes:

- The battery capacity is defined by the 20 hour rate
- The oil specification should be for the minimum ambient temperature as the oil will not be warmed by the immersion heater
- Breakaway current is dependant on battery capacity available. Cables should be capable of handling the transient current which may be up to double the steady cranking current.

Lubrication system

Recommended multigrade oil viscosity (15W40) which adequately meets the specifications of API CG4. For further details refer to the engine OMM.

Lubricating oil capacity

Total system... 177 litres
Sump maximum ... 157,5 litres
Sump minimum ... 115 litres
Oil temperature at normal operating conditions ... 95 °C
Oil temperature (in rail) - maximum continuous operation . 105 °C

Lubricating oil pressure

minimum ... 340 kPa
At rated speed... 450 kPa
Oil relief opens ... 400 kPa
Oil filter screen spacing. ... 20 microns
Sump drain plug tapping size ... G1
Lubricating oil pump speed ... 1.4 x engine rev/min
Lubricating oil pump drive method ... engine driven
Shutdown switch - pressure setting (where fitted) 193 kPa (falling)

Normal operating angles

-front and rear ... 5°
-side tilt... 10°

Oil consumption (prime power)

After running-in (typically after 250 hours) ... g/kW hr 1.8
Oil flow rate from oil pump ... l/s 7,0

Energy balance

4012-46TWG4A

Designation	Units	Prime power	Standby power
Energy in fuel	kWt	3238	3516
Energy in power output (gross)	kWb	1308	1396
Energy to cooling fan	kWm	54	
Energy in power output (nett)	kWm	1254	1342
Energy to exhaust	kWt	1118	1220
Energy to coolant and oil	kWt	472	500
Energy to radiation	kWt	65	100
Energy to charge cooler	kWt	275	300

Exhaust system

Outlet size (internal) ... 254 mm
Outlet flange size ... 10" table D
Total exhaust back pressure ... 5,0 kPa
For pipe sizes, refer to 'Installation Manual'

Induction system

Emissions data with combustion air temperature of 25 °C

Maximum air intake restriction of engine:

-clean filter ... 2,0 kPa
-dirty filter ... 4,0 kPa
-air filter type... cylindrical paper pleat

Noise

Noise measured in semi reverberant environment and measured at a distance of 1 metre from the periphery of the engine

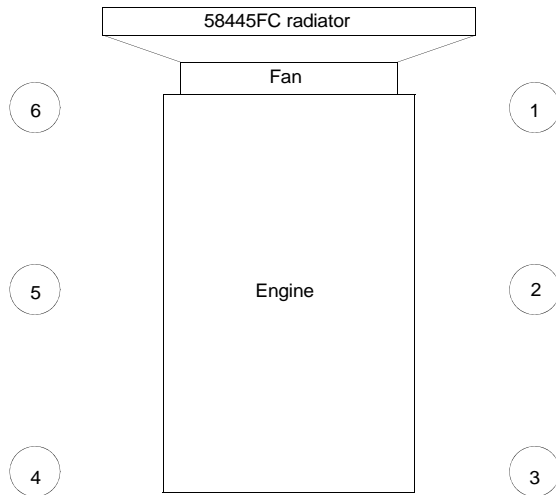

Noise measured at points 1 - 6 @ 1396 kWb gross	
Position	d(B)A
1	112.9
2	113.6
3	81.3
4	111.6
5	114.8
6	112.5

Frequency analysis @ Point 2 1434 kWb gross	
Hz	d(B)A
31.5	95.4
63	97.0
125	95.0
250	103.6
500	109.6
1k	102.7
2k	100.7
4k	97.0
8k	94.0
16k	84.0

Noise levels

The figures for noise levels are typical for an engine running at standby power rating in a semi-reverberant environment and measured at a distance of one metre from the periphery of the engine.

Total noise level

Sound pressure level re: -20x10Pa
Ambient noise level 84 d(B)A
Octave analysis performed at the position of maximum noise.

Typical load acceptance (cold)

Engine type	Initial load acceptance when engine reaches rated speed (15 seconds maximum after engine starts to crank)				2nd load application immediately after engine has recovered to rated speed (5 seconds after initial load application)			
	Prime power %	Load kWe nett	Transient frequency deviation %	Frequency recovery time seconds	Prime power %	Load kWe nett	Transient frequency deviation %	Frequency recovery time seconds
4012-46TWG4A	70	840	≤ 10	5	30	360	≤ 10	5

The above figures were obtained under test conditions as follows:

- Engine block temperature 45 °C
- Ambient temperature 15 °C
- Governing mode Isochronous
- Alternator inertia. 50 kgm²
- Under frequency roll off (UFRO) point set to 1 Hz below rated
- UFRO rate set to 2% voltage / 1% frequency
- LAM on / off On

All tests were conducted using an engine installed and serviced to Perkins Engines Company Limited recommendations.
Applied load is a percentage of generator electrical output efficiency as published in the general installation section of this data sheet.
The information given on this Technical Data Sheet is for standard engines, and for guidance only.
For ratings other than those shown contact Perkins Engines Company Limited, Stafford.

Perkins®
Perkins Engines Company Limited
Peterborough PE1 5NA United Kingdom
Telephone +44 (0) 1733 583000
Fax +44 (0) 1733 582240
www.perkins.com

Distributed by

All information in the document is substantially correct at the time of printing but may be subsequently altered by the company.